

Pompe FP 50 LC

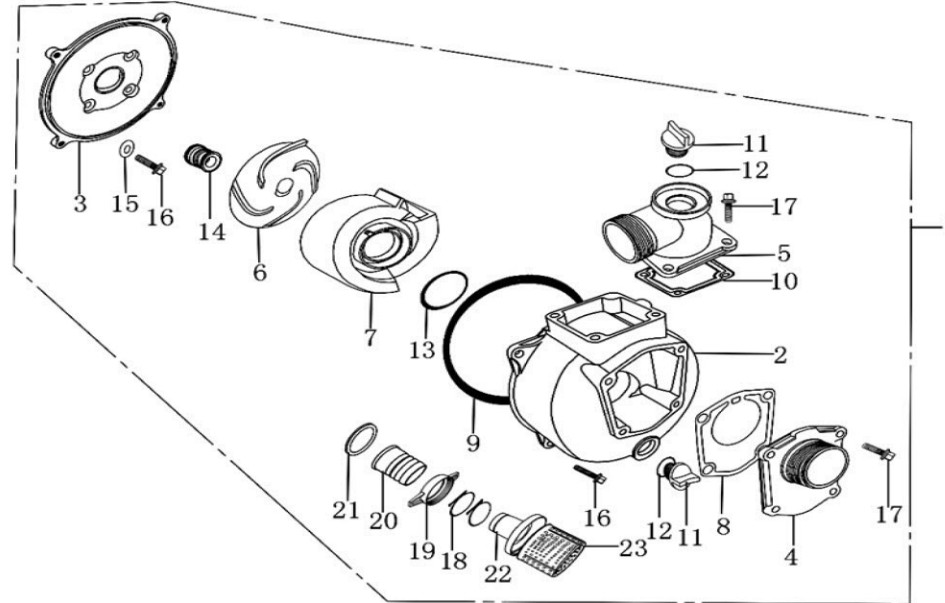

No.	Part No.	Description	Description	FP 50 LC
1	660180002-T810	POMPE COMPLETE	PUMP COMP.	1
2	660220002-T810	CARTER DE POMPE	HOUSING OF PUMP	1
3	660190002-T810	FLASQUE DE POMPE	PUMP COVER	1
4	660230001-T810	BRIDE D'ASPIRATION	FLANGE , ENDURE PRESS	1
5	660250001-T810	JOINT	FLANGE , OUTPUT	1
6	660200001-T810	TURBINE DE POMPE	WATER PUMP IMPELLER	1
7	660210001-T810	VOLUTE	VOLUTE CASING	1
8	660320001-T810	CLAPET ANTI-RETOUR	CHECK VALVE	1
9	380840459-T810	JOINT TORIQUE	O-RING 196×4	1
10	660260002-T810	JOINT	SEAL , OUTPUT	1
11	660240001-T810	BOUCHON	PLUG	2
12	380840501-T810	JOINT	O-RING 25×4	2
13	380840460-T810	JOINT	O-RING 57.5×6	1
14	660350001-T810	JOINT MECANIQUE	MACHINERY SEAL	1

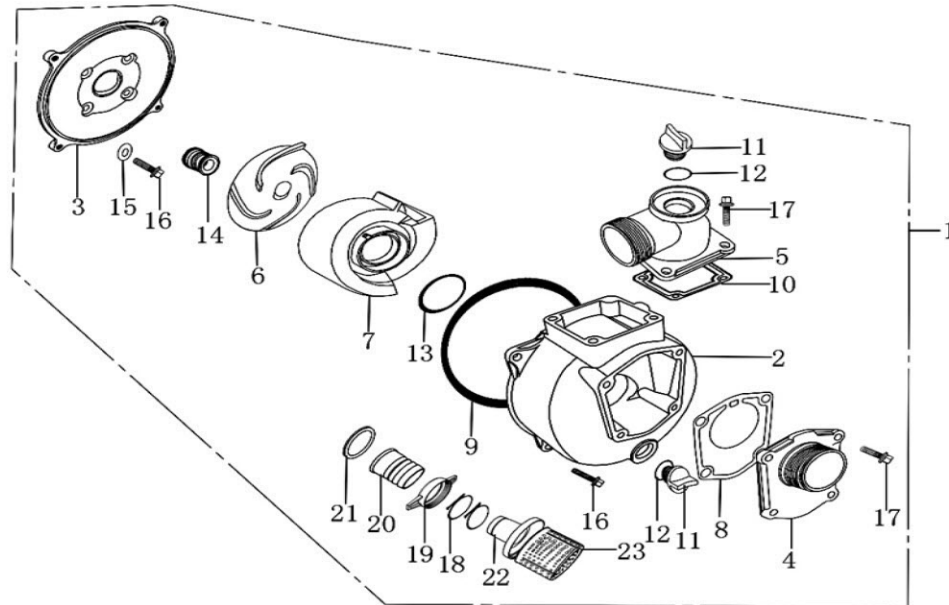

No.	Part No.	Description	Description	FP 50 LC
15	660830001-T810	RONDELLE	WASHER	4
16	380140091-0005	BOULON	BOLT,FLANGE	8
17	380140070-0004	BOULON M8 x 20	BOLT , 8×20	8
18	380960127-T810	COLLIER	LOOP , TUBE	3
19	660270011-T810	ECROU DE RACCORD	LINKER , TUBE	2
20	660280010-T810	RACCORD	TIE-IN , TUBE	2
21	380840439-T810	JOINT	SEAL , LINKER	2
22	660290011-T810	COUVERCLE DE CREPINE	COVER , FILTER	1
23	660300011-T810	CREPINE	FILTER	1